



PROJECT CONCEPT NOTE

CARBON OFFSET UNIT (CoU) PROJECT



**Title: 15 MW Karikayam Small Hydro Power Project
at Ayyappa Hydro Power Limited by Energy Advisory Services Pvt Ltd**

Version 1.0

Date 18/03/2024

First CoU Issuance Period: 10 years, 5 months

Date: 29/08/2013 to 31/12/2023



Project Concept Note (PCN)
CARBON OFFSET UNIT (CoU) PROJECT

BASIC INFORMATION

Title of the project activity	15 MW Karikayam Small Hydro Power Project at Ayyappa Hydro Power Limited by Energy Advisory Services Pvt Ltd
Scale of the project activity	Small Scale
Completion date of the PCN	18/03/2024
Project participants	<p>NAME OF OWNER: Ayyappa Hydro Power Limited, EDCL House,1 A, Elgin Road, Kolkata 700020</p> <p>AGGREGATOR: Energy Advisory Services Pvt. Ltd. Bangalore, Karnataka. Email: manoj@easpl.co.in</p>
Host Party	INDIA
Applied methodologies and standardized baselines	<p>Applied Baseline Methodology: AMS-I. D: “Grid connected renewable electricity generation”, version 18</p> <p>Standardized Methodology: Not Applicable.</p>
Sectoral scopes	01 Energy industries (Renewable/Non-Renewable Sources)
Estimated amount of total GHG emission reductions	2013: 11,509 CoUs (11,509 tCO ₂ eq)
	2014: 26,363 CoUs (26,363 tCO ₂ eq)
	2015: 23,661 CoUs (23,661 tCO ₂ eq)
	2016: 20,299 CoUs (20,299 tCO ₂ eq)
	2017: 31,027 CoUs (31,027 tCO ₂ eq)
	2018: 43,374 CoUs (43,374 tCO ₂ eq)
	2019: 26,529 CoUs (26,529 tCO ₂ eq)
	2020: 32,258 CoUs (32,258 tCO ₂ eq)
	2021: 47,960 CoUs (47,960 tCO ₂ eq)
	2022: 45,108 CoUs (45,108 tCO ₂ eq)
	2023: 34,894 CoUs (34,894 tCO ₂ eq)
	Total: 3,42,982 CoUs (3,42,982 tCO₂eq)

SECTION A. Description of project activity

A.1. Purpose and general description of Carbon offset Unit (CoU) project activity >>

The proposed project titled under UCR is “15 MW Small Hydro Power Project at M/s Ayyappa Hydro Power Limited by Energy Advisory Services”, which is a hydroelectric power project located in Karikkayam, Chittar Taluk: Rani, District Pathanamthitta, state Kerala. The project is an operational activity with continuous reduction of GHG, currently being applied under “Universal Carbon Registry” (UCR).

Purpose of the project activity:

The project activity is a renewable power generation activity that incorporates the installation and operation of Three hydro turbines, having aggregated installed capacity of 3Nos *5 MW = 15 MW in the Taluk: Rani, District Pathanamthitta, state Kerala - India. This project is promoted by M/s Ayyappa Hydro Power Limited. This project activity is also called as Karikayam Small Hydro Power Project.

The hydroelectric turbine No. 2 was Synchronization on 29/08/2013, hydroelectric turbine No. 3 was Synchronization on 02/09/2013 and hydroelectric turbine No. 1 was Synchronization on 28/09/2013 and declared the Commercial Operation Date by KSEB: Kerala State Electricity Board Limited on Company Limited, with whom the Power Purchase Agreement was concluded.

The project activity aims to harness kinetic energy of water (renewable source) from Kakkad river to generate electricity. As the nature of the hydro project, no fossil fuel is involved for power generation in the project activity, the electricity produced by the project is directly contributing to climate change mitigation by reducing the anthropogenic emissions of greenhouse gases into the atmosphere by displacing an equivalent amount of power at the grid, which would otherwise have been generated from fossil fuel-based power plants which are connected to the Indian grid system.

The net generated electricity from the project activity is sold to state electricity board through the Power Purchase Agreement (PPA) signed between the project developer and the KSEB: Kerala State Electricity Board Limited.

In pre-project scenario, electricity delivered to the grid by the project activity would have otherwise been generated by the operation of fossil fuel-based grid-connected power plants and by the addition of new generation sources in the grid.

Hence, project activity is displacing the estimated annual net electricity generation i.e., 34,645 MWh/y from the regional grid, which otherwise would have been generated by the operation of fossil fuel-based grid-connected power plants. The estimated annual average and the total CO₂e emission reductions per year, by the project activity are expected to be around 31,180 tCO₂e.

A.2 Do no harm or Impact test of the project activity>>

This project is a Greenfield activity where grid power is the baseline. The Indian grid system has been predominantly dependent on fossil fuel-powered plants. Renewable power generation is gradually contributing to the share of clean & green power in the grid; however, the grid emission factor is still on the higher side which defines the grid as a distinct baseline.

Social well-being: The project would help in generating direct and indirect employment benefits accruing out of maintenance during the operation of the project activity. It will lead to the development of infrastructure around the project area in terms of improved road network etc.

Economic well-being: The project is a clean technology investment decision based on carbon revenue support, which signifies the flow of clean energy investments into the host country. The project activity requires temporary and permanent, skilled and semi-skilled manpower at the project location; this will create additional employment opportunities in the region.

In addition, improvement in infrastructure will provide new opportunities for industries and economic activities to be set up in the area. Apart from getting better employment opportunities, the local people will get better prices for their products/land, thereby resulting in overall economic development.

Technological well-being: The project activity employs state of art technology hydro turbines which has high power generation potential. The successful operation of project activity would lead to the promotion of this technology and would further push R&D efforts by technology providers to develop more efficient and better machinery in the future. Hence, the project leads to technological well-being.

Environmental well-being: The project activity will generate power using zero emissions hydro-based power generation facility which helps to reduce GHG emissions and specific pollutants like SO_x, NO_x, and SPM associated with the conventional thermal power generation facilities. The project utilizes kinetic energy of flowing water for generating electricity which is a clean source of energy. Thus, the project causes no negative impact on the surrounding environment contributing to environmental well-being.



There was no harm identified from the project and hence no mitigation measures are applicable.

Rational: As per 'Central Pollution Control Board (Ministry of Environment & Forests, Govt. of India)', the final document on the revised classification of Industrial Sectors under Red, Orange, Green and White Categories (07/03/2016), has been declared that Hydro project activity falls under the "White category".

White Category projects/industries do not require any Environmental Clearance such as 'Consent to Operate' from PCB as such project does not lead to any negative environmental impacts. Additionally, as per Indian Regulations, Environmental and Social Impact Assessment is not required for Hydro Power projects.

The Government of India has stipulated the following indicators for sustainable development in the interim approval guidelines for such projects which are contributing to GHG mitigations. The Ministry of Environment, Forests & Climate Change has stipulated economic, social, environmental, and technological well-being as the four indicators of sustainable development.

It has been envisaged that the project shall contribute to sustainable development using the following ways:

<p>7 AFFORDABLE AND CLEAN ENERGY</p> 	<ul style="list-style-type: none"> • The project activity has generated 34,645 MWh of clean energy per year, which with increased shared will increase the affordability at a cheaper rate to end user. • The project activity will utilize Hydro energy (renewal resource) to generate power. The project activity will increase the share of renewable resource-based electricity in global mix of energy consumption.
<p>8 DECENT WORK AND ECONOMIC GROWTH</p> 	<ul style="list-style-type: none"> • Decent work and economic growth. The project activity generates additional employment for skilled and unskilled, also the project situated in a remote area will provide employment opportunities to unskilled people from villages. • Training on various aspects including safety, operational issues, and developing skill sets will also be provided to employees.
<p>13 CLIMATE ACTION</p> 	<ul style="list-style-type: none"> • This Hydro power project meets the SDG 13 goal by saving fossil fuel and producing clean energy. • This project has avoided 31,180 tons of CO2 emissions so far up to Dec'23 during this monitoring period. In a Greenfield project, electricity delivered to the grid by the project would reduce the dependence on fossil fuel-based generation units and as there are no associated emissions with this project it contributes to the reduction of greenhouse gases (GHG) emissions.

A.3. Location of project activity >>

Country:	India
Village:	PO Karikkayam, Chittar
Tehsil:	Rani
District:	Pathanamthitta
State:	Kerala
Pincode	689663
Coordinates	9°20'07.4"N 76°53'59.5"E

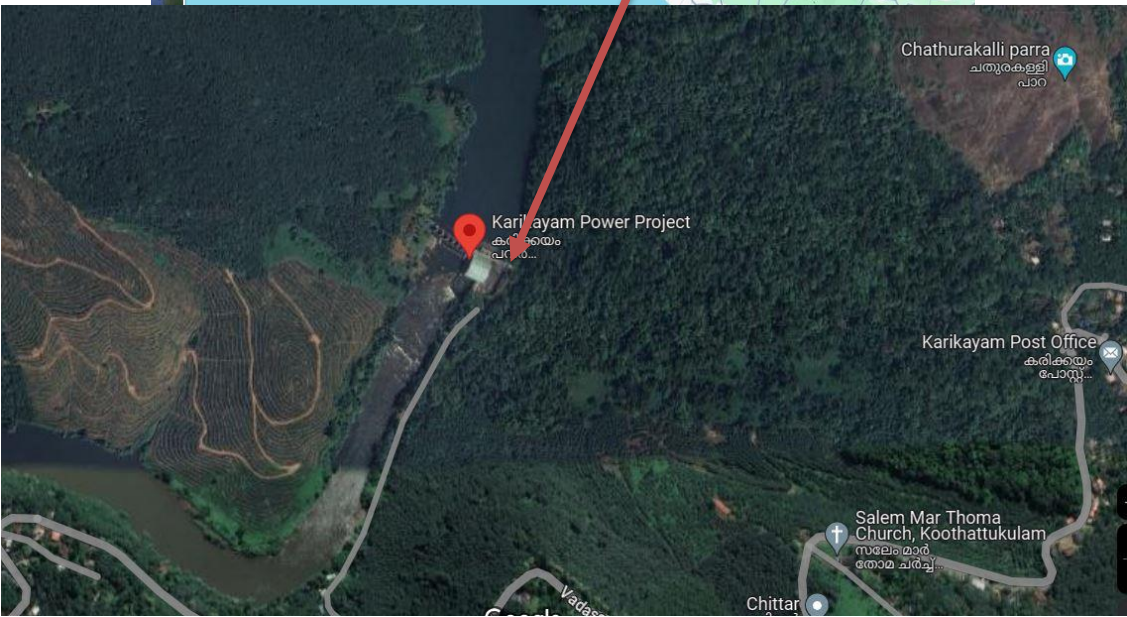
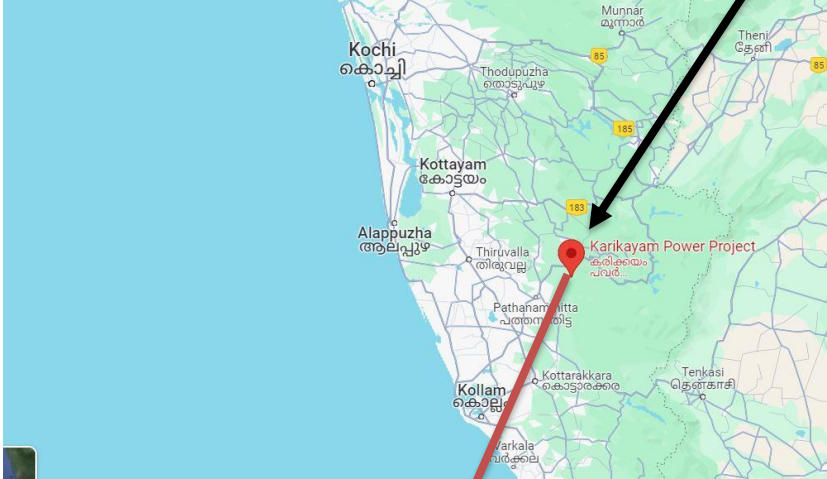
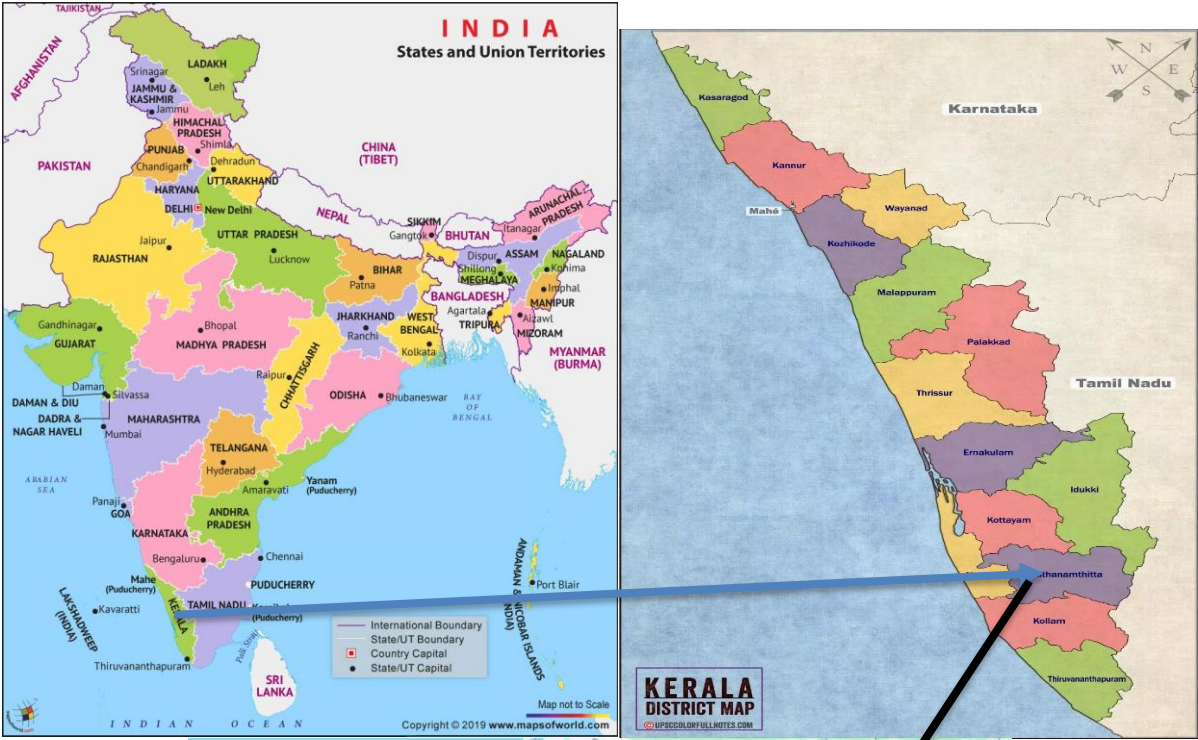

A.4. Technologies/measures >>

The project activity involves one Horizontal Kaplan Turbine of 3 Nos. * 5 MW (15MW), with alternator, internal electrical lines connected to the 110 kV /110kV substation at Pathanamthitta. The generators generate power at 11 kV, which is stepped up to 110kV using transformer at the generation station. The project activity operates at a frequency of 50 Hz and a voltage of 11 kV. The average life of the generator is around 35 to 40 years as per the equipment supplier specification.

The other salient features of the technology are:

Particular	Value
Turbine	
Make	ANDRITZ MAKE
Type	S TYPE FULL KAPLAN
Rated Capacity	6000KW
Generator	
Make	TD Power Systems
Rated Capacity	5882 KVA
Serial No	2K811663-01,02,03
Full Load Efficiency	98%
Gear Box	
Make	M/S Triveni Engineering
Rated Power	5000 KW
Input/Output Speed	213/750 RPM

A.5. Parties and project participants >>

Party (Host)	Participants
INDIA	<p>NAME OF OWNER: Ayyappa Hydro Power Limited, EDCL House,1 A, Elgin Road, Kolkata 700020</p> <p>AGGREGATOR: Energy Advisory Services Pvt. Ltd. Bangalore, Karnataka. Email: manoj@easpl.co.in</p>

A.6. Baseline Emissions>>

The baseline scenario identified at the PCN stage of the project activity is:

In the absence of the project activity, the equivalent amount of electricity would have been imported from the grid (which is connected to the unified Indian Grid system (NEWNE Grid)), which is carbon intensive due to being predominantly sourced from fossil fuel-based power plants. Hence, the baseline scenario of the project activity is the grid-based electricity system, which is also the pre-project scenario.

Schematic diagram showing the baseline scenario:

BASILINE SCENARIO
Electricity provided to the grid by more-GHG-intensive means.

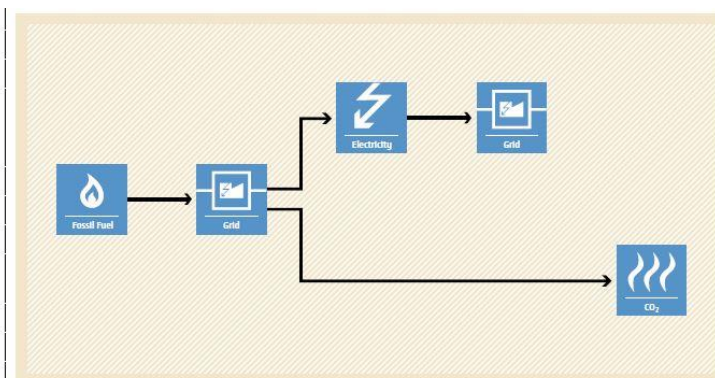

PROJECT SCENARIO
Electricity is generated and supplied to the grid using renewable energy technologies.

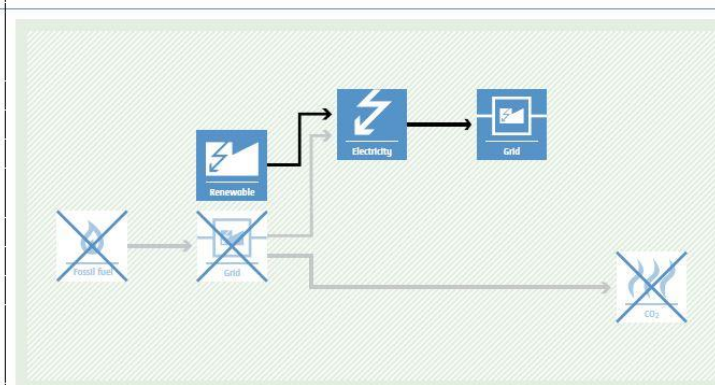

A.7. Debundling>>

This project activity is not a de-bundled component of a larger project activity.

SECTION B. Application of methodologies and standardized baselines

B.1. References to methodologies and standardized baselines >>

SECTORAL SCOPE	01, Energy industries (Renewable/Non-renewable sources)
TYPE	I – Renewable Energy Projects
CATEGORY	AMS. I.D. (Title: “Grid connected renewable electricity generation”, version 18)

B.2. Applicability of methodologies and standardized baselines >>

Applicability Criterion	Project Case
<p>1. This methodology comprises renewable energy generation units, such as photovoltaic, hydro, tidal/wave, wind, geothermal and renewable biomass:</p> <p>(a) Supplying electricity to a national or a regional grid; or</p> <p>(b) Supplying electricity to an identified consumer facility via national/regional grid through a contractual arrangement such as wheeling.</p>	<p>The project activity is a renewable energy project i.e. Small Hydro Power which falls under applicability criteria option 1 (a) i.e., “Supplying electricity to a national or a regional grid”.</p> <p>Hence the project activity meets the given applicability criterion.</p>
<p>2. This methodology is applicable to project activities that:</p> <p>(a) Install a Greenfield plant;</p> <p>(b) Involve a capacity addition in (an) existing plant(s);</p> <p>(c) Involve a retrofit of (an) existing plant(s);</p> <p>(d) Involve a rehabilitation of (an) existing plant(s)/unit(s); or</p> <p>(e) Involve a replacement of (an) existing plant(s).</p>	<p>The option (a) of applicability criteria 2 is applicable as project is a Greenfield plant/Unit.</p> <p>Hence the project activity meets the given applicability criterion.</p>
<p>3. Hydro power plants with reservoirs that satisfy at least one of the following conditions are eligible to apply this methodology:</p> <p>(a) The project activity is implemented in existing reservoir, with no change in the volume of the reservoir; or</p> <p>(b) The project activity is implemented in existing reservoir, where the volume of the reservoir(s) is increased and the power density as per definitions given in the project emissions section, is greater than 4 W/m².</p> <p>(c) The project activity results in new reservoirs and the power density of the power plant, as per definitions given in the project emissions section, is greater than 4W/m².</p>	<p>This Small-Scale Hydro Project is implemented on a small river in upstream of a reservoir, in hilly terrain as a run of river type and thus this project does not change in the water volume in the existing reservoir established in downstream of the plant. Thus, criteria 3(a) is applicable.</p>
<p>4. If the new unit has both renewable and non-renewable components (e.g., a wind/diesel unit), the eligibility limit of 15 MW for a small-scale CDM project activity applies only to the</p>	<p>The proposed project is 15 MW Small Hydro Power Project, i.e., only component is renewable power project below 15MW, thus this criterion is not applicable to this project</p>

renewable component. If the new unit co-fires fossil fuel, the capacity of the entire unit shall not exceed the limit of 15 MW.	activity.
5. Combined heat and power (co-generation) systems are not eligible under this category.	The project is Small Hydro Power Project and thus, this criterion is not applicable to this project activity.
6. In the case of project activities that involve the capacity addition of renewable energy generation units at an existing renewable power generation facility, the added capacity of the units added by the project should be lower than 15 MW and should be physically distinct from the existing units.	The proposed project is a greenfield 15 MW - Small Hydro Power Project, and it does not involve capacity addition to an existing power plant. Thus, this criterion is not applicable to this project activity.
7. In the case of retrofit, rehabilitation or replacement, to qualify as a small-scale project, the total output of the retrofitted, rehabilitated or replacement power plant/unit shall not exceed the limit of 15 MW.	The proposed project is a greenfield 15 MW Small Hydro Power Project, i.e., no retrofit, rehabilitation or replacement was done to any existing power plant. Thus, this criterion is not applicable to this project activity.
8. In the case of landfill gas, waste gas, wastewater treatment and agro-industries projects, recovered methane emissions are eligible under a relevant Type III category. If the recovered methane is used for electricity generation for supply to a grid, then the baseline for the electricity component shall be in accordance with procedure prescribed under this methodology. If the recovered methane is used for heat generation or cogeneration other applicable Type-I methodologies such as “AMS-I.C.: Thermal energy production with or without electricity” shall be explored.	The proposed project is a greenfield 15 MW Small Hydro Power Project hence, this criterion is not applicable to this project activity.
9. In case biomass is sourced from dedicated plantations, the applicability criteria in the tool “Project emissions from cultivation of biomass” shall apply.	No biomass is involved, the project is only a Hydro Power Project and thus this criterion is not applicable to this project activity.

B.3. Applicability of double counting emission reductions >>

The project was not applied under any other GHG mechanism. Hence project will not cause double accounting of carbon credits (i.e., COUs), due to the following reasons:

- Project is uniquely identifiable based on its location coordinates,
- Project has a dedicated commissioning certificate and connection point,
- Project is associated with energy meters which are dedicated to the consumption point for the project developer.

B.4. Project boundary, sources and greenhouse gases (GHGs)>>

As per applicable methodology AMS-I.D. Version 18, “The spatial extent of the project boundary includes the project power plant and all power plants connected physically to the electricity system that the project power plant is connected to.”

Thus, the project boundary includes the hydropower plant and the transmission line including metering up to the substation.

The project boundary includes the physical, geographical site(s) of:

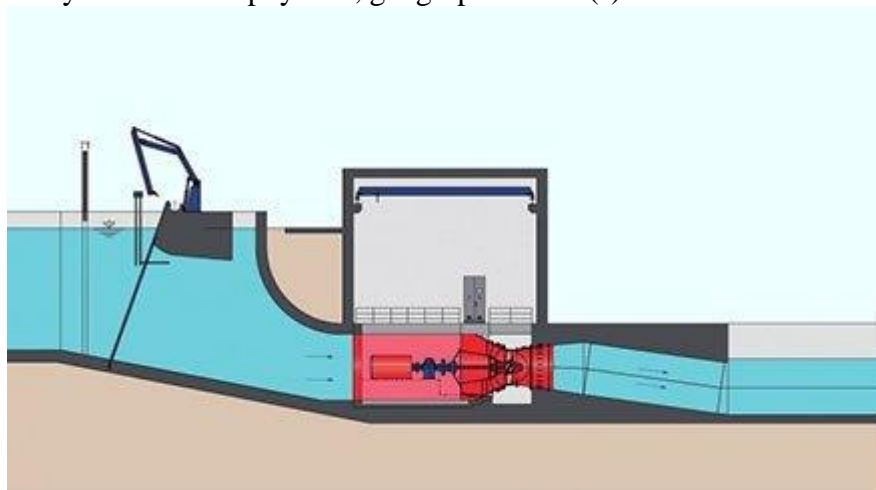

Summary of gases and sources included in the project boundary, and justification explanation where gases and sources are not included

	<i>Source</i>	<i>GHG</i>	<i>Included?</i>	<i>Justification/Explanation</i>
<i>Baseline</i>	<i>Emissions from grid connected power plants using non-renewable energy sources as fuel</i>	<i>CO₂</i>	<i>Included</i>	<i>Major source of emission</i>
		<i>CH₄</i>	<i>Excluded</i>	<i>Negligible source of emission</i>
		<i>NO₂</i>	<i>Excluded</i>	<i>Minor source of emissions</i>
		<i>Others</i>	<i>Excluded</i>	<i>No other GHG emissions were emitted from the project</i>
<i>Project Activity</i>	<i>Emissions from on-site electricity use</i>	<i>CO₂</i>	<i>Excluded</i>	<i>Project activity does not emit CO₂</i>
		<i>CH₄</i>	<i>Excluded</i>	<i>Project activity does not emit CH₄</i>
		<i>NO₂</i>	<i>Excluded</i>	<i>Project activity does not emit NO₂</i>
		<i>Others</i>	<i>Excluded</i>	<i>Project activity does not emit any other GHG gases</i>

B.5. Establishment and description of baseline scenario >>

As per the approved consolidated methodology AMS-I.D. Version 18, if the project activity is the installation of a new grid-connected renewable power plant/unit, the baseline scenario is the following:

“The baseline scenario is that the electricity delivered to the grid by the project activity would have otherwise been generated by the operation of grid-connected power plants and by the addition of new generation sources into the grid”.

The project activity involves setting up a new hydropower plant to harness the kinetic energy of flowing water. In the absence of the project activity, the equivalent amount of power would have been supplied by the Indian grid, which is fed mainly by fossil fuel-fired plants. Hence, the baseline for the project activity is the equivalent amount of power produced at the Indian grid.

A "grid emission factor" refers to a CO₂ emission factor (tCO₂/MWh) that will be associated with each unit of electricity provided by an electricity system. The UCR recommends an emission factor of 0.9 tCO₂/MWh for the 2013-2023 years as a conservative estimate for Indian projects not previously verified under any GHG program. Also, for the vintage 2022-2023, the combined margin emission factor calculated from the CEA database in India results in higher emissions than the default value. Hence, the same emission factor has been considered to calculate the emission reduction under a conservative approach.

B.5.1 Net GHG Emission Reductions and Removals

Thus, $ER_y = BE_y - PE_y - LE_y$

Where:
 ER_y = Emission reductions in year y (tCO₂/y)
 BE_y = Baseline Emissions in year y (t CO₂/y)
 PE_y = Project emissions in year y (tCO₂/y)
 LE_y = Leakage emissions in year y (tCO₂/y)

• Baseline Emissions

Baseline emissions include only CO₂ emissions from electricity generation in power plants that are displaced due to the project activity. The methodology assumes that all project electricity generation above baseline levels would have been generated by existing grid-connected power plants and the addition of new grid-connected power plants.

The baseline emissions are to be calculated as follows:

$$BE_y = EG_{PJ,y} \times EF_{grid,y}$$

BE_y = Baseline emissions in year y (t CO₂)

$EG_{PJ,y}$ = Quantity of net electricity generation that is produced and fed into the grid as a result of the implementation of the CDM project activity in year y (MWh)

$EF_{grid,y}$ = UCR recommended emission factor of **0.9 tCO₂/MWh** has been considered.
(Reference: General Project Eligibility Criteria and Guidance, UCR Standard, page 4)

Estimated annual baseline emission reductions (BE_y)

$$\begin{aligned} &= 34,645 \text{ MWh/year} * 0.90 \text{ tCO}_2/\text{MWh} \\ &= 31,180 \text{ tCO}_2/\text{y} \end{aligned}$$

• Project Emissions Calculation

As per Paragraph 39 of AMS-I.D. version-18, only emissions associated with fossil fuel combustion, emissions from the operation of geothermal power plants due to the release of non-condensable gases, and emissions from a water reservoir of hydro should be accounted for the project emission. Since the project activity is a hydroelectric power project, project emission for renewable energy plants is nil.

Thus, PE = 0

• Leakage Emission Calculation

As per paragraph 42 of AMS-I.D. version-18, 'If the energy generating equipment is transferred from another activity, leakage is to be considered.' In the project activity, there is no transfer of energy generating equipment and therefore the leakage from the project activity is considered zero.

Hence, LE = 0

• Net Emission

The actual emission reduction achieved during the first CoU period shall be submitted as a part of the first monitoring and verification. However, for the purpose of an ex-ante estimation, the following calculation has been submitted:

Hence,

Net GHG emission reduction, = **31,180** - 0 - 0 = **31,180 tCO₂** (i.e., **31,180** CoUs)

B.6. Prior History>>

The project activity is a small-scale hydro project and was not applied under any other GHG mechanism prior to this registration with UCR. Also, the project has not been applied for any other environmental crediting or certification mechanism.

Hence the project will not cause double accounting of carbon credits (i.e., CoUs).

B.7. Changes to start date of crediting period >>

There is no change in the start date of crediting period.

The start date of crediting under UCR is considered as 29/08/2013, which is the project's first monitoring date.

B.8. Permanent changes from PCN monitoring plan, applied methodology or applied standardized baseline >>

There are no permanent changes from registered PCN monitoring plan and applied methodology.

B.9. Monitoring period number and duration>>

First Issuance Period: 10 years, 5 months – 29/08/2013 to 31/12/2023

B.8. Monitoring plan>>

USE THE FOLLOWING TABLES TO FOR PARAMETERS BEING MONITORED OR USED IN EMISSION REDUCTIONS DETERMINATION

Parameter	<i>EG_{PJ,y}</i>
Data unit	MWh
Description	Quantity of net electricity generation that is produced and fed into the grid because of the implementation of this project activity in year y.
Source of data Value(s) applied	Monthly Joint meter reading documents.
Procedures	The Net electricity generation by the hydro power plant is recorded at the sub-station. At the end of every month Electrical distribution company notes down the meter readings and generate the joint meter reading (JMR) report based on the monthly electricity exported to the grid or consumed by the nearby local community.
Monitoring frequency	Monthly
Purpose of data	To calculate the baseline emission

Parameter	<i>EF_{grid,y}</i>
Data and Parameters available at validation (ex-ante values)	UCR recommended emission factor
Data unit	tCO ₂ /MWh
Description	A "grid emission factor" refers to a CO ₂ emission factor (tCO ₂ /MWh) which will be associated with each unit of electricity provided by an electricity system. The UCR recommends an emission factor of 0.9 tCO ₂ /MWh for the 2016 - 2022 years as a conservative estimate for Indian projects not previously verified under any GHG program. Hence, the same emission factor has been considered to calculate the emission reduction under conservative approach.
Source of data	https://cea.nic.in/wp-content/uploads/baseline/2023/01/Approved_report_emission_2022_23.pdf and UCR Document
Value applied	0.9
Measurement methods and procedures	-
Monitoring frequency	Ex-ante fixed parameter
Purpose of Data	For the calculation of Emission Factor of the grid
Additional Comment	The combined margin emission factor as per CEA database (current version 19, Year 2023) results into higher emission factor. Hence for 2023 vintage UCR default emission factor remains conservative.

Data/Parameter	Date of commissioning of the units
Data unit	Date
Description	Actual date of commissioning of the project unit
Source of data Value(s) applied	Commissioning report issued by State grid transmission corporation or State electricity board
Measurement methods and procedures	The construction processes are maintained from its initiation to completion dates for the Hydro unit. Thus, the start date of each of the unit installed is recorded in the monitoring report.
Monitoring frequency	As and when commissioned and fixed and recorded in the monitoring report
Purpose of data	To estimate baseline emissions