



PROJECT CONCEPT NOTE

CARBON OFFSET UNIT (CoU) PROJECT



Title: 4 MW Wind Power Project by GFL Gujarat, India

Version 1.0

Date of PCN: 17th Oct 2023

1st CoU Issuance Period: 08.10.2013 to 31.12.2022 (9 Years 02 month 23 days)

1st Monitoring Period: 08.10.2013 to 31.12.2022 (9 Years 02 month 23 days)

1st Crediting Period: 08.10.2013 to 31.12.2022 (9 Years 02 month 23 days)

8 DECENT WORK AND
ECONOMIC GROWTH

13 CLIMATE
ACTION

7 AFFORDABLE AND
CLEAN ENERGY





Project Concept Note(PCN)
CARBON OFFSET UNIT(CoU)PROJECT

BASIC INFORMATION

Title of the project activity	4 MW Wind Power Project GFL, Gujarat, India.
Scale of the project activity	Small Scale
Completion date of the PCN	17/10/ 2023
Project Participants	<p>Project Proponents:M/s.Gujarat Fluorochemicals Limited, Inox Towers, Noida, Uttar Pradesh, India.</p> <p>UCR Aggregator: Inox Green Energy Service Limited UCRID: 724964927</p>
Host Party	India
Applied methodologies and standardized baselines	<p>Type (Renewable Energy Projects)</p> <p>UNFCCC Methodology AMS-1.D: “Grid connected renewable electricity generation”, Version 18</p> <p>UCR Protocol Standard Baseline</p>
Sectoral scopes	01Energyindustries(Renewable/Non Renewable Sources)
SDG Impacts:	<p>SDG7 Affordable and Clean energy</p> <p>SDG8 Decent work and economic growth</p> <p>SDG 13 Climate Action</p>
Estimated amount of total GHG emission reductions per year	5278 CoUs / Yr (5278 tCO₂eq/Yr)

SECTION A. Description of project activity

A.1. Purpose and general description of Carbon offset Unit(CoU) project activity

The project activity titled **4 MW Wind Power Project by Gujarat Fluorochemicals Limited, Gujarat** is renewable (wind) energy projects located at the following locations in Country: India:

SrNo	Name of Wind Farm	Installed Capacity(MW)	Village/s	District	State
01	Gujarat Fluorochemicals Limited	4	Veraval & Kidi	Rajkot& Amreli	Gujarat

The wind farm is owned by Gujarat Fluorochemicals Limited., (GFL- Project Proponent or PP), which is a subsidiary of Inox Wind Ltd (IWL) and Inox Green Energy Service Ltd (IGESL), which is a part of Inox GFL Group. The Group is an Indian conglomerate with a legacy of more than 90 years. The group is a forerunner in diversified business segments comprising Fluor polymers, Specialty Chemicals, Wind Energy, and Renewable in various geographies. The total installed capacity of the GFL Wind Project is 4 MW wind power project in Rajkot & Amreli district of Gujarat. The GFL Wind Projects consists of 2 WTGs of 2.0 MW each. The entire Engineering, Procurement and Construction (EPC) are provided by Inox Wind Ltd & Operations and Maintenance (O&M) services are provided by Inox Green Energy Service Ltd.

The generated electricity from the WTGs is grid connected wind power project located in Veraval village of Rajkot & Kidi village of Amreli District in the state of Gujarat (India). The purpose of this plant installation to supply electricity to regional GETCO Grid or wheeled for captive consumption through wheeling into the grid and M/s has the full ownership of the project activity. The wind power projects are operational activities with continuous reduction of GHGs, currently being applied for voluntary carbon offset units (CoUs) under “Universal Carbon Registry” (UCR). **The commissioning date of the first WTG considered as the start date of the project activity and is recorded as (08.10.2013)**

In the absence of the project activity, electricity would have been delivered to the grid by the operation of fossil fuel-based grid-connected power plants and by the addition of new fossil fuel-based generation sources in the Grid. As is the nature of wind projects (renewable energy), no fossil fuel is involved for power generation in the project activity. The electricity produced by the project is directly contributing to climate change mitigation by reducing the anthropogenic emissions of greenhouse gases (GHGs, i.e., CO₂) into the atmosphere by displacing an equivalent amount of power at grid.

The project activity is hence the installation of new grid connected renewable power plants/units. The baseline scenario and scenario existing prior to the implementation of the project activity are both the same.

The project activity is displacing an estimated annual net electricity generation i.e., 5864 MWh / Yr from the Indian grid system, which otherwise would have been generated by the operation of fossil fuel-based grid-connected power plant. The estimated annual average CO₂e emission reductions by the project activity are expected to be 5278 tCO₂e / Yr, whereas actual emission reduction achieved during the first CoU period shall be submitted as a part of first monitoring and verification.

Since the project activity will generate electricity through wind energy, a clean renewable energy source it does not cause any negative impacts on the environment and thereby contributes to climate change mitigation efforts.

The Owner of the project is Ms.Gujarat Fluorochemicals Limited. The details along with commissioning period are as follows:

Sr.No	WTG No	COD	Village	Tehsil	District	State
1	PT-T-01	08/10/2013	Veraval	Jasdan	Rajkot	Gujarat
2	PTT-113	03/02/2016	Kidi	Babra	Amreli	Gujarat

Project's Contribution to Sustainable Development

Indian economy is highly dependent on “Coal” as fuel to generate energy and for production processes. Thermal power plants are the major consumers of coal in India and yet the basic electricity needs of a large section of population are not being met. This results in excessive demands for electricity and places immense stress on the environment.

Changing coal consumption patterns will require a multi-pronged strategy focusing on demand, reducing wastage of energy and the optimum use of renewable energy (RE) sources. This project activity is a green field activity where fossil grid power is the baseline. The renewable power generation is gradually contributing to the share of clean & green power in the grid; however, grid emission factor is still on higher side which defines the grid as distinct baseline.

The Government of India has stipulated following indicators for sustainable development in the interim approval guidelines for such projects which are contributing to GHG mitigations. The Ministry of Environment, Forests & Climate Change, has stipulated economic, social, environment and technological well-being as the four indicators of sustainable development. It has been envisaged that the project shall contribute to sustainable development using the following ways:

Social well-being:

- Social well being is assessed by contribution by the project activity towards improvement in living standards of the local community, temporary and permanent basis.
- The project activity has resulted in increased job opportunities for the local population on temporary and permanent basis.
- Manpower was required both during erection and operation of the wind farms. This has resulted in poverty alleviation of the local community and development of basic infrastructure leading to improvement in living standards of the local population.

Economic well being

- The project activity has created direct and indirect job opportunities to the local community during installation and operation of the WEGs.
- The investment for the project activity has increased the economic activity of the local area.
- The project activity also contributes in economic well being of the nation's economy by reducing import of fossil fuel for electricity generation in hard currency

Environmental well being

- The project utilizes wind energy for generating electricity which otherwise would have been generated through alternate fuel (most likely - fossil fuel) based power plants, contributing to reduction in specific emissions (emissions of pollutant/unit of energy generated) including GHG emissions.
- As wind power projects produce no end products in the form of solid waste (ash etc.), they address the problem of solid waste disposal encountered by most other sources of power.
- Being a renewable resource, using wind energy to generate electricity contributes to resource conservation. Thus, the project activity causes no negative impact on the surrounding environment.

Technological well being

- There is continuous research and development on the geometry of the wind blades, height of towers, diameters of towers, etc., which augurs well for the technological well-being in the development of wind energy to produce clean electricity.
- The generated electricity from the project activity is connected to the grid. The project activity improves the supply of electricity with clean, renewable wind power while contributing to the regional/local economic development
 - Wind Energy plants provide local distributed generation, and provide site-specific reliability and transmission and distribution benefits including:
 1. Improved power quality
 2. Reactive power control
 3. Mitigation of transmission and distribute on congestion

With regards to ESG credentials:

At present specific ESG credentials have not been evaluated, however, the project essentially contributes to various indicators which can be considered under ESG credentials. Some of the examples are as follows:

Under Environment:

The following environmental benefits are derived from the project activity:

- i. Produces renewable electricity without any GHG emissions.
- ii. Wind power plants have little impact on the surrounding ecology.

For the PPs, energy sale pattern is now based on renewable energy due to the project and it also contributes to GHG emission reduction and conservation of depleting energy sources associated with the project baseline. Hence, project contributes to ESG credentials..

A.2 Do no harm or Impact test of the project activity.

There are social, environmental, economic and technological benefits which contribute to sustainable development. Rational: As per ‘Central Pollution Control Board (Ministry of Environment & Forests, Govt. of India)’, final document on revised classification of Industrial Sectors under Red, Orange, Green and White Categories (07/03/2016), it has been declared that wind project activity falls under the “White category”.

White Category projects/industries do not require any Environmental Clearance such as ‘Consent to Operate’ from PCB as such project does not lead to any negative environmental impacts. Additionally, as per Indian Regulation, Environmental and Social Impact Assessment is not required for Wind Projects.

United Nations Sustainable Development Goals :

The project activity generates electrical power using wind energy which is generated from windmills, there by displacing non-renewable fossil resources resulting to sustainable, economic and environmental development. In the absence of the project activity equivalent amount of power generation would have taken place through fossil fuel dominated power generating stations.

Thus, the renewable energy generation from project activity will result in reduction of the greenhouse gas emissions. Positive contribution of the project to the following Sustainable Development Goals:

SDG13: Climate Action

SDG7: Affordable and Clean Energy

SDG8: Decent Work and Economic Growth

Development Goals	Targeted SDG	Target Indicator (SDG Indicator)
 <p>SDG13: Climate Action</p>	<p>13.2: Integrate climate change measures international policies strategies and planning</p> <p>Target: 5278 tCo2/annum</p>	<p>13.2.1: Number of countries that have communicated establishment or operationalization of an integrated policy/ strategy/ plan which increases their ability to adapt to the adverse impacts of climate change, and foster climate resilience and low greenhouse gas emissions development in a manner that does not threaten food production (including a national adaptation plan, nationally determined contribution, national communication, biennial update report or other)</p>

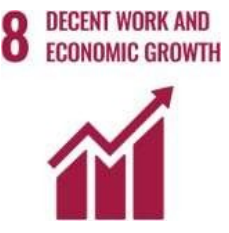
 <p>SDG7: Affordable and Clean Energy</p>	<p>7.2: By 2030, increase substantially the share of renewable energy in the global energy mix</p> <p>Target: 5864 MWh / Annum</p>	<p>7.2.1: Renewable energy share in the total final energy consumption</p>
 <p>SDG8: Decent Work and Economic Growth</p>	<p>8.5: By 2030, achieve full and productive employment and decent work for all women and men, including for young people and persons with disabilities, and equal pay for work of equal value Target: Training</p> <p>Target: Training, O & M staff</p>	<p>8.5.1: Average hourly earnings of female and male employees, by occupation, age and persons with disabilities.</p>

A.3. Location of Project activity>>

Country: India

Sr No	Name of Wind Farm	Installed Capacity (MW)	Villages	District	State
01	Gujarat Fluorochemicals Limited.	4	Veraval & Kidi	Rajkot & Amreli	Gujarat

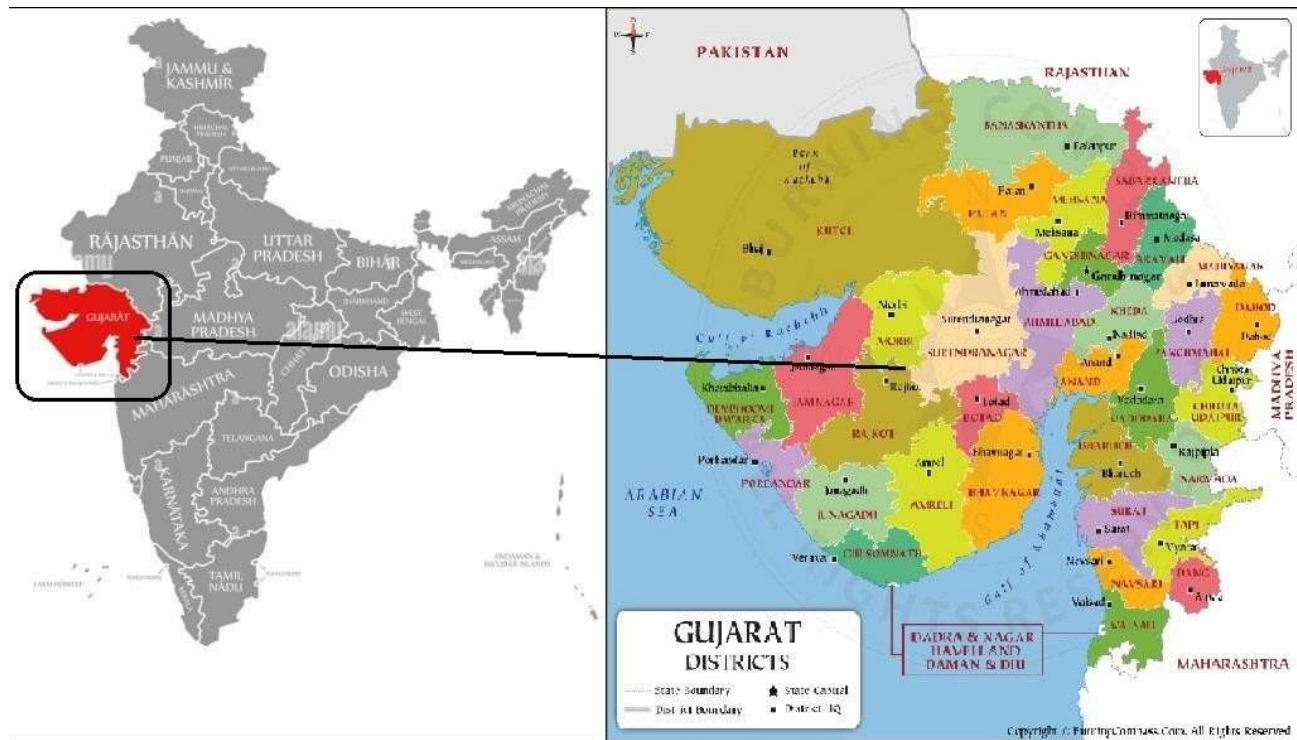

Figure-1-Location of the project activity (courtesy:googleimagesandwww.mapofindia.com)

Gujarat Fluorochemicals Limited					
Sr.No.	WTG No.	INST_CAPACITY (MW)	WTG_MODEL_NAME	Longitude	Latitude
1	PT-T-01	2	IWISL/2000/13-14/3306	71.320081	21.950576
2	PTT-113	2	IWISL/2000/2015-16/3703	71.100081	22.228576



IMAGE- GFL WTG

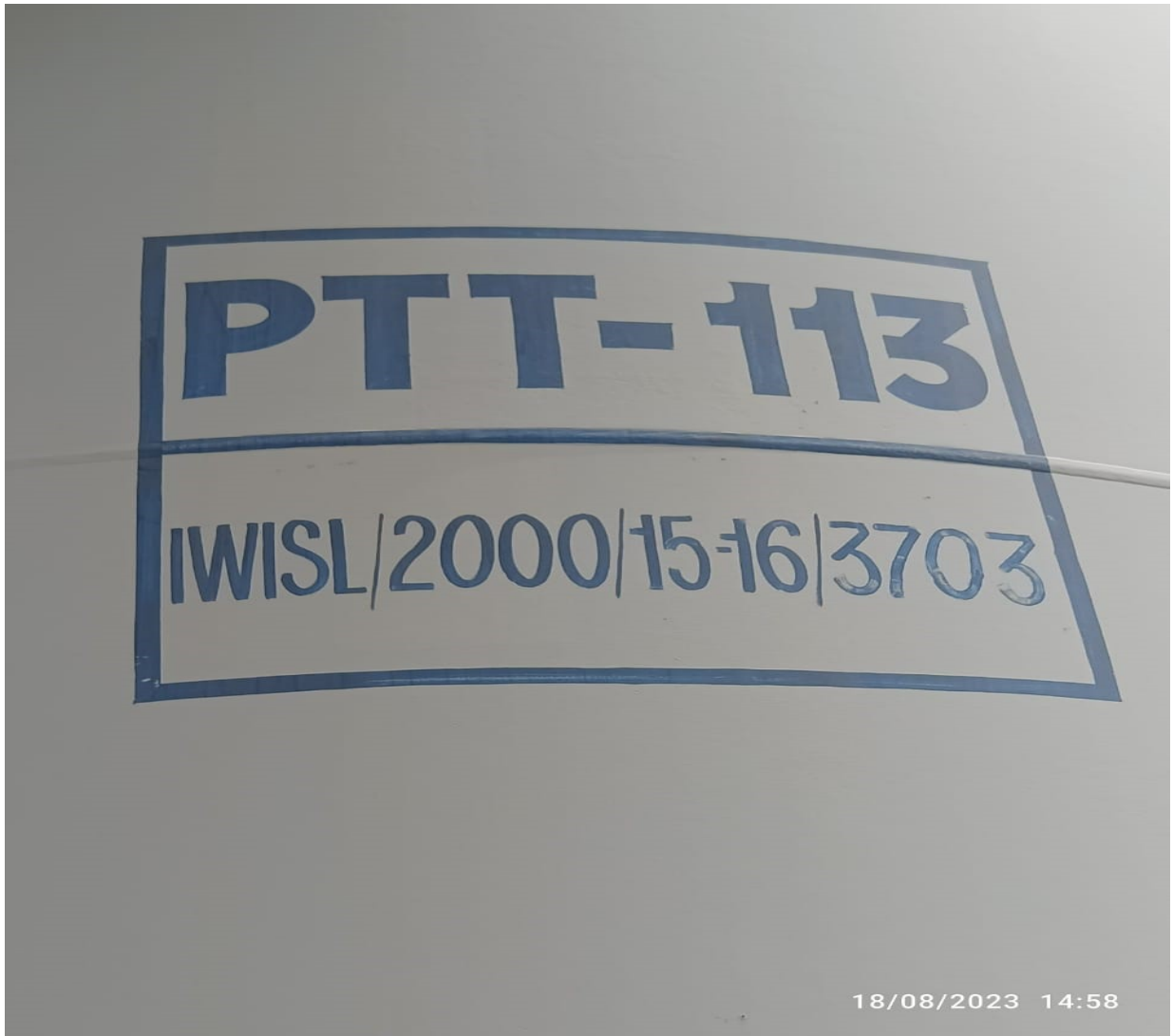

IMAGE-GFL WTG



IMAGE – GFL WTG

A.4. Technologies/measures

All the machines are INOX make and have been developed using state of the art technology. In wind energy generation, kinetic energy of wind is converted into mechanical energy and subsequently into electrical energy. Wind has considerable amount of kinetic energy when blowing at high speeds. This kinetic energy when passes through the blades of the WEG is converted into mechanical energy and rotates the wind blades. When the wind blades rotate, the connected generator also rotates, thereby producing electricity. The technology is a clean technology since there are no GHG emissions associated with the electricity generation.

The important parts of a windmill are:

Main Tower This is a very tall structure with a ladder at the bottom. The ladder is used for operation and maintenance

Blades The WEGs are provided with three blades. The blades are self-supporting in nature made up of Fiber Reinforced Polyester. The blades are mounted on the hub.

Nacelle The Nacelle is the one which contains all the major parts of a WEG. The nacelle is made up of thick rugged steel and mounted on a heavy slewing ring. Under normal operating conditions, the nacelle would be facing the upstream wind direction.

Hub The Hub is an intermediate assembly between the wing and the main shaft of the wind turbine. Inside the hub, a system to actuate the aerodynamic brake is fitted. The hub is covered with nose cone.

Main Shaft The shaft is to connect the gear box and the hub. Solid high carbon steel bars or cylinders are used as main shaft. The shaft is supported by two bearings.

Gear Box, Bearing and Housing The gearbox is used to increase the speed ratio so that the rotor speed is increased to the rated generator speed. Oil cooling is employed to control the heating of the gearbox. Gearboxes are mounted over dampers to minimize vibration. The main bearings are placed inside housing.

Brake Brake is employed in the WEGs to stop the wind turbine mainly for maintenance check. Brakes are also applied during over speed conditions of the wind turbine. The brakes are placed on the high-speed shaft.

Generator The generator uses induction type of generator. The generators are provided with monitoring sensors in each phase winding to prevent damage to the generators.

In the absence of the project activity the equivalent amount of electricity would have otherwise been generated by the operation of fossil fuel-based grid-connected power plants and fed into unified India grid system, hence baseline scenario of the project activity is the grid-based electricity system, which is also the pre-project scenario as discussed in the previous section.

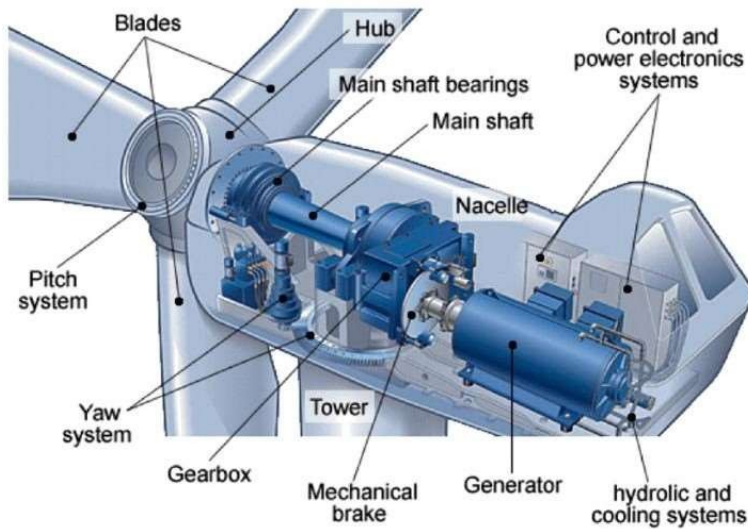
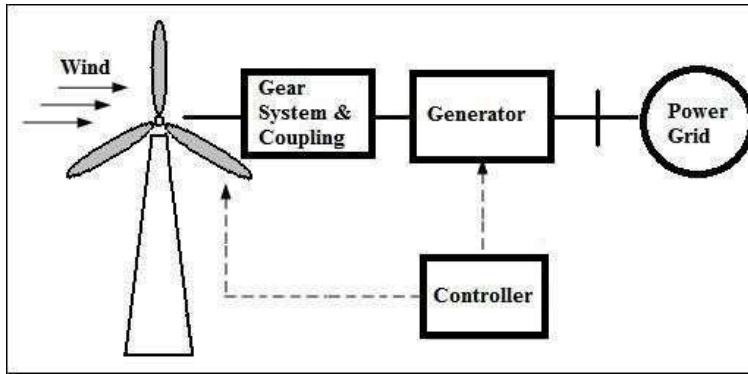

Process Flow Technical Specifications

Model		
1	Turbine Model	InoxDF2000-WT100
Operating Data		
2	Rated power	2000kW
3	Cut in wind speed	3.0m/s
4	Rated wind speed	11.0m/s
5	Cut-out Wind speed	20.0m/s
6	Hub Height	92m
7	Class	III B
Rotor		
8	Rotor Diameter	100 m
9	Rotor Area	6795 m ²
10	No of Rotor blade	3
11	Blade length	45.3 m
Generator		
12	Type	Doubly fed induction generator (DFIG)

13	Rated power	2000kW
Tower		
14	Type	Conical tubular steel tower
15	Hub height	80m
Braking system		
16	Operational brake	Full span blade pitching
17	Type of construction	gear/servomotor

A.5. Parties and project participants >>

Party(Host)	Participants
India	<p>Project Proponents -Ms. Gujarat Fluorochemicals Limited, Inox Towers, Noida, Uttar Pradesh, India</p> <p>UCR Aggregator: Inox Green Energy Service Limited UCRID: 724964927 Email: sk.mathu@inoxwind.com</p>

A.5. Baseline Emissions

In the absence of the project activity, the equivalent amount of electricity would have been imported from the regional grid (which is connected to the unified Indian Grid system (NEWNE Grid)), which is carbon intensive due to predominantly sourced from fossil fuel based power plants. Hence, baseline scenario of the project activity is the grid-based

BASELINE SCENARIO

Thermal energy would be produced by more-GHG-intensive means based on the use of non-renewable biomass.

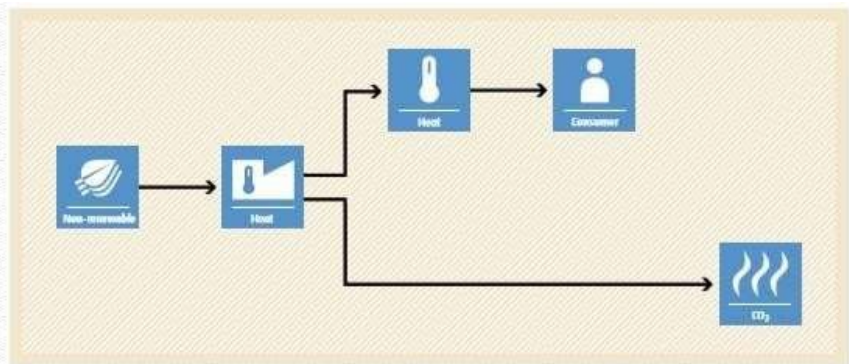

PROJECT SCENARIO

Use of renewable energy technologies for thermal energy generation, displacing non-renewable biomass use.

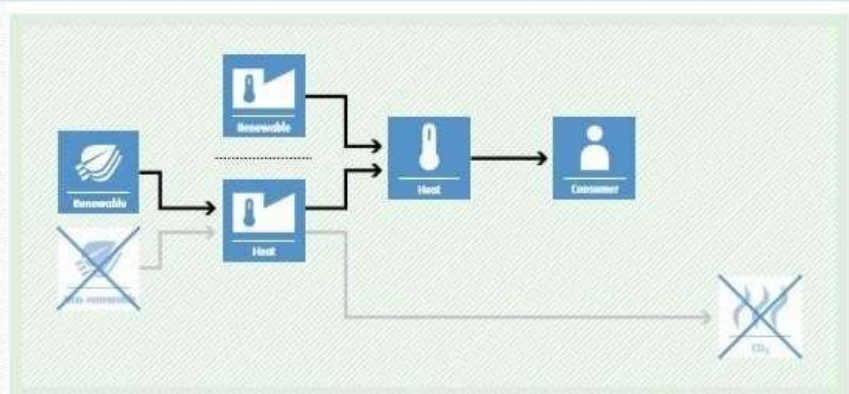

Electricity system, which is also the pre-project scenario.

A.6. Debundling

This **4MW Wind Power Project by Gujarat Fluorochemicals Limited** project is not debundled component of a larger carbon or GHG registered project activity.

SECTION B. Application of methodologies and standardized baselines

B.1. References to methodologies and standardized baselines

SectoralScope-01, Energy industries (Renewable/Non-renewable sources)

Type- I –Renewable Energy Projects

Category

AMS-I.D:“Grid connected renewable electricity generation”, version18.0 (Small Scale Consolidated Methodology)

B.2.Applicability of methodologies and standardized baselines

The project activity involves generation of grid connected electricity from the construction and operation of a new wind power based power project for captive consumption of the power at the PP’s facility. The project activity has installed capacity of 4.0 MW which will qualify for a small scale project activity under Type-I of the Small Scale methodology. The project status is corresponding to the methodology AMS-I.D., version 18 and applicability of methodology is discussed below:

This project is included within the UCR Standard Positive List of technologies and is within the Small-scale CDM thresholds (e.g., installed capacity Less than 15 MW). The UCR positive list comprises of: (a) generation of grid connected electricity from the construction and operation of a new wind power-based power project for supply to grid
Project activity involves power generation with installed capacity of 4 MW.
The project activity is a Renewable Energy Project i.e., Wind Power Project which falls under applicability criteria option1 (a) i.e., “Install a Green field power plant”. Hence the project activity meets the given applicability criteria on of AMS-I.D
The project activity is wind energy power project and not a hydro power project activity.
The project activity does not involve any retrofit measures nor any replacement to existing WEGs. Hence there are no new units having either renewable or non-renewable components (e.g., a wind/diesel unit).
The project activity is not a combined heat and power (co-generation) system.
No biomass is involved, the project is only a wind energy power project. The case for retrofit, rehabilitation or replacement, towards a Large-scale project is also not applicable.
The project activity is a voluntary coordinated action. The project activity is a greenfield of 4 MW Wind Electric Project, i.e., no capacity addition was done to any existing power plant.
The project activity is not a landfill gas, waste gas, wastewater treatment and agro-industries project,

and does not recover methane emissions and is not eligible under any relevant Type III category.

The project activity comprises of renewable power/energy generation through wind energy and displaces fossil fuel powered electricity from the regional grid by supplying renewable power to the grid itself. Hence this UNFCCC CDM Methodology is applicable and fulfilled.

The project activity involves the installation of new power plants at listed sites where there was no renewable energy power plant operating prior to implementation of project.

B.3. Applicability of double counting emission reduction

There is no double accounting of emission reductions in the project activity due to the following reasons:

- Project is uniquely identifiable based on its location coordinates,
- Project has dedicated commissioning certificate and connection point,
- Project is associated with energy meters which are dedicated to the consumption point for project developer

Further, the PP has not applied for registration or crediting under any other voluntary GHG mechanism for the current UCR monitoring and crediting period of this project activity. Hence there is no double counting of the carbon credits anticipated for the current project activity.

B.4. Project boundary, sources and greenhouse gases(GHGs)

As per applicable methodology AMS-I.D. Version 18, “The spatial extent of the project boundary includes the project power plant and all power plants connected physically to the electricity system that the project power plant is connected to.”

Thus, the project boundary includes the Wind Turbine Generators (WTGs) and the Indian grid system.

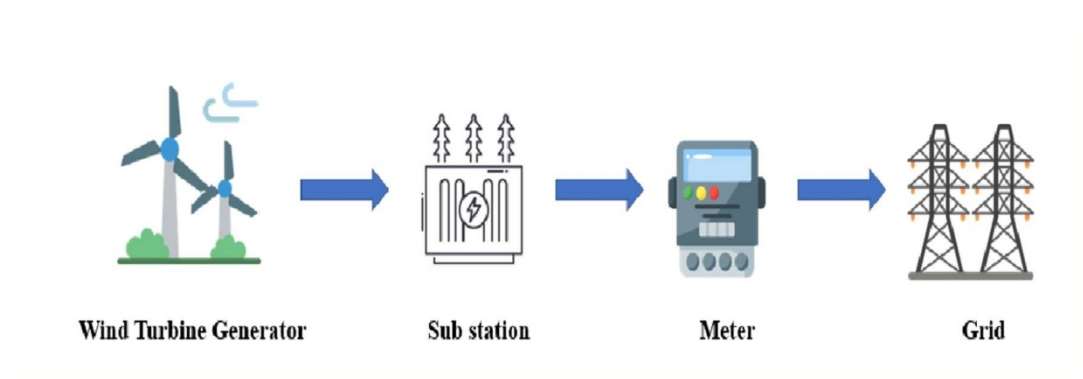

	Source	GHG	Included?	Justification/Explanation
Baseline	Grid-connected electricity	CO2	Included	Major source of emission
		CH4	Excluded	Excluded for simplification. This is conservative

		N ₂ O	Excluded	Excluded for simplification. This is conservative
Project Activity	Greenfield power project	CO ₂	Excluded	Excluded for simplification. This is conservative
		CH ₄	Excluded	Excluded for simplification. This is conservative
		N ₂ O	Excluded	Excluded for simplification. This is conservative

Net GHG Emission Reductions and Removals

Thus, $ER_y = BE_y - PE_y - LE_y$

Where:

ER_y = Emission reductions in year y (tCO₂/y)

BE_y = Baseline Emissions in year y (t CO₂/y)

PE_y = Project emissions in year y (tCO₂/y)

LE_y = Leakage emissions in year y (tCO₂/y)

B.5. Establishment and description of baseline scenario (UCR Protocol)>>

Baseline emissions include only CO₂ emissions from electricity generation in power plants that are displaced due to the project activity. The methodology assumes that all project electricity generation above baseline levels would have been generated by existing grid-connected power plants and the addition of new grid- connected power plants.

Total Installed Capacity: 4MW

Estimated Annual Emission Reductions: $BE_y = E_{GBL,y} \times EF_{CO_2, GRID, y}$

BE_y = Emission reductions in a yearly. where:

$E_{GBL,y}$ = Quantity of net electricity supplied to the grid as a result of the implementation of the UCR project activity in year (MWh)

$EF_{Grid, CO_2, y}$ = CO₂ emission factor of the grid in year y (tCO₂/MWh) as determined by the UCR Standard.

A "grid emission factor" refers to a CO₂ emission factor (tCO₂/MWh) which will be associated with each unit of electricity provided by an electricity system. The UCR recommends an emission factor of 0.9 tCO₂/MWh for the 2013-2020 years as a fairly conservative estimate for Indian projects not previously verified under any GHG program. Also, for the vintage 2021-22, the combined margin emission factor calculated from CEA database in India results into same emission factors as that of the default value. Hence, the same emission factor has been considered to calculate the emission reduction.

Project Emissions As per AMS-I.D version 18.0, only emission associated with the fossil fuel combustion, emission from operation of geo-thermal power plants due to release of non- condensable gases, emission

from water reservoir of Hydro should be accounted for the project emission

Since the project activity is a wind power project, project emission for renewable energy plant is nil. Thus, $PE_y=0$.

Leakage As per AMS-I.D version 18.0, ‘If the energy generating equipment is transferred from another activity, leakage is to be considered.’ In the project activity, there is no transfer of energy generating equipment and therefore the leakage from the project activity is considered as zero. Hence, $LE_y=0$

The actual emission reduction achieved during the first crediting period shall be submitted as a part of first monitoring and verification. However, for the purpose of an ex-ante estimation, following calculation has been submitted:

Estimated annual Emission Reductions (ER_y)=5278 tCO₂/year

B.6. Changes to start date of crediting period>>

There is no change in the start date of crediting period. The start date of crediting under UCR is considered as 08/10/2013, which is the commissioning date of the earliest commissioned wind turbine and no GHG emission reduction has been claimed so far under any other voluntary GHG program.

B.8. Permanent changes from PCN monitoring plan, applied methodology or applied standardized baseline>>

There are no permanent changes from registered PCN monitoring plan and applied methodology

B.9. Monitoring period number and duration>>

1stMonitoringPeriod:08.10.2013 to 31.12.2022 (9 Years 02 month 23 days)

1stCreditingPeriod:08.10.2013 to 31.12.2022 (9 Years 02 month 23 days)

B.10. Monitoring plan

Key Data Monitored: • Quantity of net electricity supplied to the grid

1. Monitoring Plan Objective and Organization

PPs are the project implementers and monitors the electricity delivered to the electricity grid by the project activity. The data is already archived electronically and is stored since **08.10.2013**.

To ensure that the data is reliable and transparent, the PPs have established Quality Assurance and Quality Control (QA&QC) measures to effectively control and manage data reading, recording, auditing as well as archiving data and all relevant documents. The data is monitored on a daily basis and is submitted to PPs on a daily basis.

PPs have implemented QA&QC measures to calibrate and ensure the accuracy of metering and safety aspects of the project operation. The metering devices are calibrated and inspected properly and periodically, according to state electricity board’s specifications and requirements to ensure accuracy in the readings.

2. Data and Parameters to be monitored

The project activity essentially involves generation of electricity from wind, the employed WEGs can only convert wind energy into electrical energy and cannot use any other input fuel for electricity generation. Thus, no special ways and means are required to monitor leakage from the project activity. The recording of the electricity fed to the state utility grid is carried out jointly at the incoming feeder of the state power utility. The joint measurement is carried out once in a month in presence of both parties (the developer's representative and officials of the state power utility). Both parties sign the recorded reading.

Data/Parameter:	EGy
Data unit:	MWh
Description:	Quantity of net electricity supplied by the Project Activity to the grid in year y
Source of data:	JMR. Statement of net export of power to the grid issued Monthly by State Electricity Board or any other competent authority as applicable.
Measurement procedures(if any):	To be specified by State Electricity Board
Monitoring frequency:	<p>The net energy exported to the grid is measured every month using calibrated energy meter by the State Electricity Board authorities in the presence of the project implementer or its representatives. The meter/s shall be jointly inspected, and sealed by authorized representatives of the company and the state utility.</p> <p>Measuring procedure: Will be measured by an export-import energy meter. The net electricity exported by the project plant would either be directly sourced as a measured parameter or be calculated by deducting the amount of imported electricity from the total amount of exported electricity.</p> <p>Accuracy class of energy meter: As per Power Purchase Agreement (PPA) or relevant National standards amended/modified from time to time.</p> <p>Calibration Frequency: As per the Central Electricity Authority the testing and calibration frequency should be minimum once in five years. However, the calibration will be done following the relevant applicable National Guidelines updated from time to time during the operation of the project activity.</p> <p>Entity responsible: Aggregator</p>

QA/QC procedures:	Monitoring frequency: Continuous Measurement frequency: Hourly Recording frequency: Monthly The electricity meter/s record both export and import of electricity from the solar Power plant and the readings with regard to net electricity generated will be used for calculation of emission reductions. The net electricity supplied to the grid will be cross checked with the monthly invoices. The meter/s would be checked for accuracy and the meters will be calibrated as per the procedures of State Electricity Board as per the national or international standards. Measurement results shall be cross
Purpose of Data	Calculation of baseline emissions

Data/Parameter	EF, CO ₂ , GRID, y
Data unit	tCO ₂ /MWh
Description	Fixed Ex-Ante
Of data Value(s) applied	UCR Standard Protocol As per Standard
Measurement methods and procedures	Fixed
Monitoring frequency	NA
Purpose of data	To estimate baseline emissions