



# PROJECT CONCEPT NOTE

## CARBON OFFSET UNIT (CoU) PROJECT

**Title: 6.3 MW Bundled Small Scale Wind Power Project by M/s Hanumantha Rao**

Version 1.0

Date: 31/08/2022

First CoU Issuance Period: 07 Years 11 Months

Crediting Period: 16/02/2015 to 31/12/2022



### BASIC INFORMATION

Title of the project activity	6.3 MW Bundled Small Scale Wind Power Project by M/s Hanumantha Rao
Scale of the project activity	Small Scale
Completion date of the PCN	31/08/2022
Project participants	Project Proponent: M/s M. Hanumantha Rao Aggregator: Energy Advisory Services Pvt. Ltd.
Host Party	India
Applied methodologies and standardized baselines	<b>CDM UNFCCC Methodology</b> <b>AMS-I.D.:</b> Grid connected renewable electricity generation version-18 & UCR Standard for Emission Factor
Sectoral scopes	01 Energy industries (Renewable/Non-Renewable Sources)
Estimated total amount of average GHG emission reductions per year	9,933 tCO <sub>2</sub> eq or 9,933 CoUs
<b>Estimated total amount of average GHG emission reductions for the entire monitoring period</b>	66,526 tCO <sub>2</sub> eq or 66,526 CoUs

## SECTION A. Description of project activity

### A.1. Purpose and general description of Carbon offset Unit (CoU) project activity >>

The Project Titled “6.3 MW Bundled Small Scale Wind Power Project by M/s Hanumantha Rao” is a Wind based Power Project successfully commissioned by Karnataka Power Transmission Corporation Limited (KPTCL) and operational since 16/02/2015. The Project is owned by M/s Hanumantha Rao (hereby to be called as Project Proponent, PP).

#### **Purpose of the project activity:**

The purpose of the project activity is to utilize renewable wind energy for generation of electricity. The project activity replaces anthropogenic emissions of greenhouse gases (GHG's) into the atmosphere, by displacing the equivalent amount of electricity generation through the operation of existing fuel fossil fuel-based power plants and future capacity expansions connected to the grid. In the absence of the project activity the equivalent amount of electricity would have been generated from the fossil fuel-based power plant. Whereas the electricity generation from operation of Wind Energy Convertors (WEC's) is emission free. Commissioning dates of the Wind Turbine Generators installed are shown in the below table:

Sr. No.	RR. No	No. & Capacity	Commissioning Date
1	GDG/DN/WF/HESCOM/MHR-168	1 X 2100 kW	16/02/2015
2	GDG/DN/WF/HESCOM/MHR-171	1 X 2100 kW	31/03/2015
3	GDG/DN/WF/HESCOM/MHR-173	1 X 2100 kW	29/09/2015

The project will generate approximately 11,037 MWh of electricity per annum. The net generated electricity from the project activity is for captive consumption by the project proponent. Wheeling agreement is signed between PP and Karnataka Power Transmission Corporation Limited (KPTCL). The project activity has been helping in greenhouse gas (GHG) emission reduction by using renewable resources (wind energy) for generating power which otherwise would have been generated using grid mix power plants, which is dominated by fossil fuel based thermal power plants. The estimated annual average and the total CO<sub>2e</sub> emission reduction by the project activity is expected to be 9,933 t/CO<sub>2</sub>, whereas actual emission reduction achieved during the first CoU period shall be submitted as a part of first monitoring and verification.

### A.2 Do no harm or Impact test of the project activity>>

There are social, environmental, economic and technological benefits which contribute to sustainable development.

#### **Social Benefits:**

- The project activity will lead to the development of supporting infrastructure such as road network etc., in the wind park location, the access to which is also provided to the local population.
- The project activity will lead to alleviation of poverty by establishing direct and indirect benefits through employment generation and improved economic activities by strengthening of local grid of the state electricity utility.
- Use of a renewable source of energy reduces the dependence on imported fossil fuels and associated price variation thereby leading to increased energy security.



Location of installed turbines:

Sr. No.	RR. No	Village
1	GDG/DN/WF/HESCOM/MHR-168	Shirunj
2	GDG/DN/WF/HESCOM/MHR-171	Kanavi
3	GDG/DN/WF/HESCOM/MHR-173	Nabapur

#### A.4. Technologies/measures >>

The bundled project activity consists of 3 Wind turbines of 2100 kW manufactured and supplied by Suzlon Energy Limited. Main component of the windmill is explained below:

##### **Main Tower**

This is a very tall structure with a door and inside ladder at the bottom. The door is used to enter into the tower for operation and maintenance.

##### **Blades**

The WEGs are provided with three blades. The blades are self-supporting in nature made up of Fiber Reinforced Polyester. The blades are mounted on the hub.

##### **Nacelle**

The Nacelle is the one which contains all the major parts of a WEG. The nacelle is made up of thick rugged steel and mounted on a heavy slewing ring. Under normal operating conditions, the nacelle would be facing the upstream wind direction.

##### **Hub**

The Hub is an intermediate assembly between the wing and the main shaft of the wind turbine. Inside the hub, a system to actuate the aerodynamic brake is fitted. The hub is covered with nose cone.

##### **Main Shaft**

The shaft is to connect the gear box and the hub. Solid high carbon steel bars or cylinders are used as main shaft. The shaft is supported by two bearings.

Some of the salient features of the project equipment can be found in the below mentioned table:

Parameter	S95-97M	
Operating Data	Wind Class	IEC IIIA
	Rated Power	2,100kw
	Cut-in Wind Speed	3.5 m/s
	Rated Wind Speed	11 m/s
	Cut-out Wind Speed	20/25 m/s
Rotor	Rotor Diameter	95/97 m
	Swept Area	7,386 m <sup>2</sup>
Generator	Frequency	50 / 60 Hz
	Type	Asynchronous 3 phase induction generator with slip ring operated with rotor circuit inverter system (DFIG)
Tower	hub Height	90 m
	Type	Tubular Steel Tower

## A.5. Parties and project participants >>

Party (Host)	Participants/Aggregator
India	<b>Project Owner:</b> M/s M. Hanumantha Rao House no.-37, Ward No-17, Ground Floor Main road, Near park, Patel Nagar, Bellary-583101, Karnataka  <b>Project Aggregator:</b> Energy Advisory Services Pvt Limited, Bangalore, Karnataka. Email: manoj@easpl.co.in

## A.6. Baseline Emissions>>

The baseline scenario identified at the PCN stage of the project activity is:

- Grid

In the absence of the project activity, the equivalent amount of electricity would have been generated from fossil fuel-based power plants and exported to the southern regional grid (which is connected to the unified Indian Grid system) as national grid is predominantly sourcing from fossil fuel-based power plants. Hence, baseline scenario of the project activity is the grid-based electricity system, which is also the pre-project scenario.

Schematic diagram showing the baseline scenario:

**Baseline Scenario:**

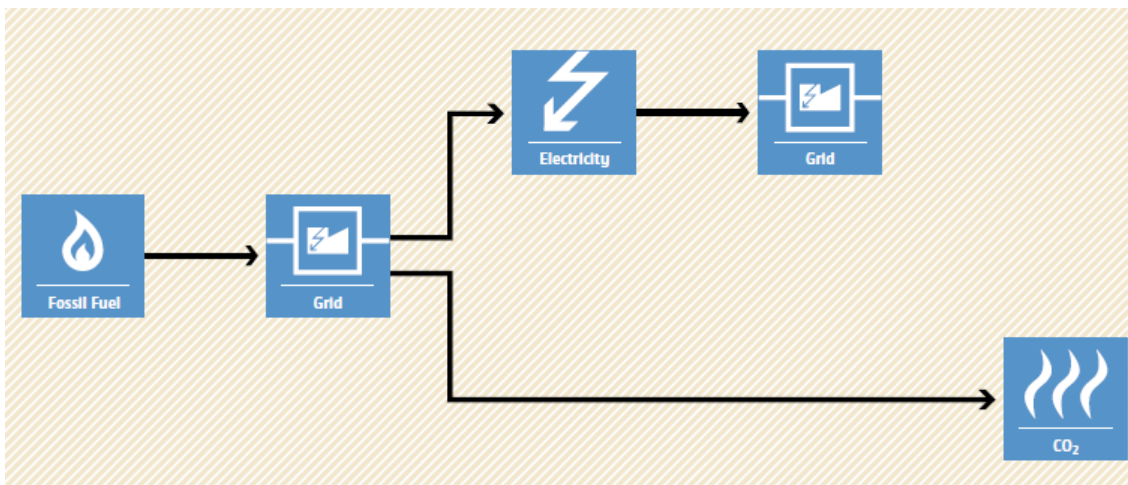

**Project Scenario:**

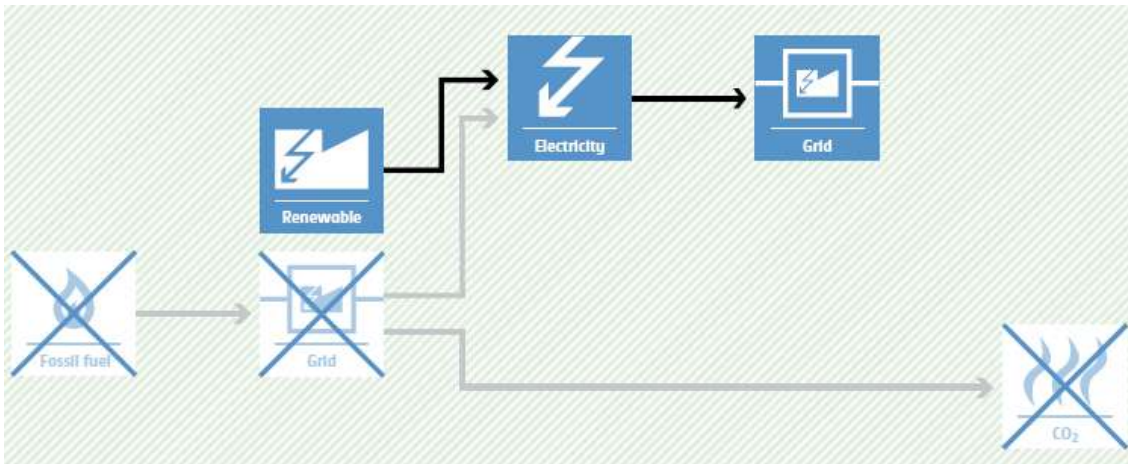

### **A.7. Debundling>>**

This project is not a debundled component of a larger registered carbon offset project activity.

## SECTION B. Application of methodologies and standardized baselines

### B.1. References to methodologies and standardized baselines >>

SECTORAL SCOPE - 01 Energy industries (Renewable/Non-renewable sources)

#### TYPE I - Renewable Energy Projects

CATEGORY- AMS-I.D.: “Grid connected renewable electricity generation” Version-18

### B.2. Applicability of methodologies and standardized baselines >>

The project activity involves generation of grid connected electricity from the construction and operation of a new wind power-based power project for captive consumption. The project activity has installed capacity of 6.3 MW which will qualify for a small-scale project activity under Type-I of the Small-Scale methodology. The project status is corresponding to the methodology AMS-I.D., version 18 and applicability of methodology is discussed below.

Applicability Criterion	Project Case
1. This methodology comprises renewable energy generation units, such as photovoltaic, hydro, tidal/wave, wind, geothermal and renewable biomass: (a) Supplying electricity to a national or a regional grid; or (b) Supplying electricity to an identified consumer facility via national/regional grid through a contractual arrangement such as wheeling.	The project activity is a Renewable Energy Project i.e., wind power project for captive consumption which falls under applicability criteria option 1 point (b). Thus, this project activity fulfills this criterion.
2. This methodology is applicable to project activities that: (a) Install a Greenfield plant; (b) Involve a capacity addition in (an) existing plant(s); (c) Involve a retrofit of (an) existing plant(s); (d) Involve a rehabilitation of (an) existing plant(s)/unit(s); or (e) Involve a replacement of (an) existing plant(s).	The option (a) of applicability criteria 2 is applicable as project is a Greenfield plant /unit. Hence the project activity meets the given applicability criterion.
3. Hydro power plants with reservoirs that satisfy at least one of the following conditions are eligible to apply this methodology: (a) The project activity is implemented in existing reservoir, with no change in the volume of the reservoir; or (b) The project activity is implemented in existing reservoir, where the volume of the reservoir(s) is increased and the power density as per definitions given in the project emissions section, is greater than 4 W/m <sup>2</sup> . (c) The project activity results in new reservoirs and the power density of the power plant, as per definitions given in the project emissions section, is greater than 4 W/m <sup>2</sup>	The project activity involves installation of Wind Turbine Generators (WTGs); hence, this criterion is not applicable.



4. If the new unit has both renewable and non-renewable components (e.g., a wind/diesel unit), the eligibility limit of 15 MW for a small-scale CDM project activity applies only to the renewable component. If the new unit co-fires fossil fuel, the capacity of the entire unit shall not exceed the limit of 15 MW.	The proposed project is 6.3 MW Wind power project, i.e., only component is renewable power project below 15MW, thus the criteria is not applicable to this project activity.
5. Combined heat and power (co-generation) systems are not eligible under this category	The project activity is wind power project thus the criterion is not applicable to this project activity.
6. In the case of project activities that involve the capacity addition of renewable energy generation units at an existing renewable power generation facility, the added capacity of the units added by the project should be lower than 15 MW and should be physically distinct from the existing units.	The proposed project is a greenfield 6.3 MW wind power project. As no capacity addition is taking place thus the criterion is not applicable to this project activity.
7. In the case of retrofit, rehabilitation or replacement, to qualify as a small-scale project, the total output of the retrofitted, rehabilitated or replacement power plant/unit shall not exceed the limit of 15 MW.	The proposed project is a greenfield 6.3 MW wind power project. As this does not involve retrofit, rehabilitation or replacement, thus the criterion is not applicable to this project activity.
8. In the case of landfill gas, waste gas, wastewater treatment and agro-industries projects, recovered methane emissions are eligible under a relevant Type III category. If the recovered methane is used for electricity generation for supply to a grid, then the baseline for the electricity component shall be in accordance with procedure prescribed under this methodology. If the recovered methane is used for heat generation or cogeneration other applicable Type-I methodologies such as “AMS-I.C.: Thermal energy production with or without electricity” shall be explored.	The proposed project is a greenfield 6.3 MW wind power project; hence, this criterion is not applicable to this project activity.
9. In case biomass is sourced from dedicated plantations, the applicability criteria in the tool “Project emissions from cultivation of biomass” shall apply.	No biomass is involved, the project is only a wind power project and thus the criterion is not applicable to this project activity.

### **B.3. Applicability of double counting emission reductions >>**

There is no double accounting of emission reductions in the project activity due to the following reasons:

- Project is uniquely identifiable based on its location coordinates,
- Project has dedicated commissioning certificate and connection point,
- Project is associated with energy meters which are dedicated to the consumption point for project developer.

#### B.4. Project boundary, sources and greenhouse gases (GHGs)>>

As per applicable methodology AMS-I.D., Version 18.0, “The spatial extent of the project boundary includes the project power plant and all power plants connected physically to the electricity system that the project power plant is connected to.”

Thus, the project boundary includes the Wind Turbine Generator (WTG) and the Indian grid system.

Source		Gas	Included?	Justification/Explanation
Baseline	Grid connected electricity generation	CO <sub>2</sub>	Yes	Main emission source
		CH <sub>4</sub>	No	Minor emission source
		N <sub>2</sub> O	No	Minor emission source
		Other	No	No other GHG emissions were emitted from the project
Project	Greenfield Wind Power Project Activity	CO <sub>2</sub>	No	No CO <sub>2</sub> emissions are emitted from the project
		CH <sub>4</sub>	No	Project activity does not emit CH <sub>4</sub>
		N <sub>2</sub> O	No	Project activity does not emit N <sub>2</sub> O
		Other	No	No other emissions are emitted from the project

#### B.5. Establishment and description of baseline scenario >>

As per the approved consolidated methodology AMS-I.D. Version 18, if the project activity is the installation of a new grid-connected renewable power plant/unit, the baseline scenario is the following: “The baseline scenario is that the electricity delivered to the grid by the project activity would have otherwise been generated by the operation of grid-connected power plants and by the addition of new generation sources into the grid”

The project activity involves setting up of a new wind power plant to harness the green power from wind energy and to use for captive purpose via grid interface through wheeling arrangement. In the absence of the project activity, the equivalent amount of power would have been supplied by the Indian grid, which is fed mainly by fossil fuel fired plants. The power produced at grid from the other conventional sources which are predominantly fossil fuel based. Hence, the baseline for the project activity is the equivalent amount of power produced at the Indian grid. A "grid emission factor" refers to a CO<sub>2</sub> emission factor (tCO<sub>2</sub>/MWh) which will be associated with each unit of electricity provided by an electricity system. The UCR recommends an emission factor of 0.9 tCO<sub>2</sub>/MWh for the 2013-2020 years as a fairly conservative estimate for Indian projects not previously verified under any GHG program. Also, for the vintage 2021, the combined margin emission factor calculated from CEA database in India results into higher emission than the default value. Hence, the same emission factor has been considered to calculate the emission reduction under conservative approach.

❖ Emission reductions are calculated as follows:

$$ER_y = BE_y - PE_y - LE_y \quad (\text{Eq. 1})$$

Where,

$ER_y$  = Emissions reductions in year y (t CO<sub>2</sub>)

$BE_y$  = Baseline emissions in year y (t CO<sub>2</sub>)

$PE_y$  = Project emissions in year y (t CO<sub>2</sub>)

$LE_y$  = Leakage emissions in year y (t CO<sub>2</sub>)

## Baseline Emissions

Baseline emissions include only CO<sub>2</sub> emissions from electricity generation in power plants that are displaced due to the project activity. The methodology assumes that all project electricity generation above baseline levels would have been generated by existing grid-connected power plants and the addition of new grid-connected power plants.

❖ The Baseline emissions in year y can be calculated as follows:

$$BE_y = EG_{PJ,y} \times EF_{grid,y} \quad (\text{Eq. 2})$$

Where,

$BE_y$	= Baseline emissions in year y (t CO <sub>2</sub> )
$EG_{PJ,y}$	= Quantity of net electricity generation that is produced and fed into the grid as a result of the implementation of the CDM project activity in year y (MWh)
$EF_{Grid,y}$	= Grid emission factor in year y (t CO <sub>2</sub> /MWh)

## Project Emissions

As per paragraph 39 of AMS-I.D. version-18, only emission associated with the fossil fuel combustion, emission from operation of geo-thermal power plants due to release of non-condensable gases, emission from water reservoir of Hydro should be accounted for the project emission. Since the project activity is a wind power project, project emission for renewable energy plant is nil

Thus,

$$PE_y = 0 \quad (\text{Eq. 4})$$

## Leakage Emissions

As per paragraph 42 of AMS-I.D. version-18, 'If the energy generating equipment is transferred from another activity, leakage is to be considered.' In the project activity, there is no transfer of energy generating equipment and therefore the leakage from the project activity is considered as zero.

Thus,

$$LE_y = 0 \quad (\text{Eq. 5})$$

## B.6. Prior History>>

The project has never applied for the GHG mechanism in the past.

## B.7. Changes to start date of crediting period >>

The start date of crediting period is 16/02/2015.

## B.8. Permanent changes from PCN monitoring plan, applied methodology or applied standardized baseline >>

There are no permanent changes from registered PCN monitoring plan and applied methodology.

## B.9. Monitoring period number and duration>>

First Issuance Period	: 07 Years 11 Months
Crediting Period	: 16/02/2015 to 31/12/2022
Monitoring Period	: 16/02/2015 to 31/12/2022

## B.10. Monitoring Plan

### Data and Parameters to be monitored

Data / Parameter	$EF_{Gridy}$
Data unit	tCO <sub>2</sub> /MWh
Description	A "grid emission factor" refers to a CO <sub>2</sub> emission factor (tCO <sub>2</sub> /MWh) which will be associated with each unit of electricity provided by an electricity system. The UCR recommends an emission factor of 0.9 tCO <sub>2</sub> /MWh for the 2013 - 2020 years as a fairly conservative estimate for Indian projects not previously verified under any GHG program. Hence, the same emission factor has been considered to calculate the emission reduction under conservative approach.
Source of data	<a href="https://a23e347601d72166dcd6-16da518ed3035d35cf0439f1cdf449c9.ssl.cf2.rackcdn.com//Documents/UCRStandardAug2022updatedVer5_030822005728911983.pdf">https://a23e347601d72166dcd6-16da518ed3035d35cf0439f1cdf449c9.ssl.cf2.rackcdn.com//Documents/UCRStandardAug2022updatedVer5_030822005728911983.pdf</a>
Value applied	0.9
Measurement methods and procedures	-
Monitoring frequency	Ex-ante fixed parameter
Purpose of Data	For the calculation of Emission Factor of the grid
Additional Comment	The combined margin emission factor as per CEA database (current version 16, Year 2021) results into higher emission factor. Hence for 2021 vintage UCR default emission factor remains conservative.

Data / Parameter	$EG_{PJ, facility, y}$
Data unit	MWh
Description	Net electricity supplied to the NEWNE grid facility by the project activity
Source of data	Joint Meter Reading Report
Measurement procedures (if any):	Data Type: Measured Monitoring equipment: Energy Meters are used for monitoring Archiving Policy: Electronic Calibration frequency: Once in 5 years (considered as per provision of CEA India).  The net electricity generated by the project activity will be calculated from net electricity supplied to grid from the share certificate issued by state utility (currently GETCO) on monthly basis for respective WTGs. The amount of energy supplied by the WTGs are continuously

	monitored and recorded once a month. The same can be cross-checked from the State utility website which is publicly available.
Measurement Frequency:	Monthly
QA/QC procedures applied:	Continuous monitoring, hourly measurement monthly recording. Tri-vector (TVM)/ABT energy meters with accuracy class 0.2s
Purpose of data:	The Data/Parameter is required to calculate the baseline emission.
Measurement Frequency:	Monthly
Value applied:	To be applied as per actual data
QA/QC procedures applied:	<p>Calibration of the Main meters will be carried out once in five (5) years as per National Standards (as per the provision of CEA, India) and faulty meters will be duly replaced immediately as per the provision of power purchase agreement.</p> <p>Cross Checking: Quantity of net electricity supplied to the grid will be cross checked from the invoices raised by the project participant to the grid.</p>
Purpose of data:	The Data/Parameter is required to calculate the baseline emission.
Any comment:	All the data will be archived till a period of two years from the end of the crediting period.